



THE DRILLING INNOVATION COMPANY™

HXI 150T Top Drive

TESCO has taken the power and performance of our most reliable top drive system and made it smaller and easier to transport - creating opportunities for smaller drilling rigs to drill farther, faster and safer. The HXI 150T is the most powerful top drive in its class.

POWERFUL

- The 700 hp system generates 24,000 ft-lbs of continuous drilling torque, ideal for shallow, extended-reach horizontal wells and maximizing ROP on vertical wells.

RELIABLE

- The HXI 150T utilizes the same hydraulic motor and gear train as the HXI 250T, which has 5 years of field-proven operation and an up-time performance rating of 99%.

VERSATILE

- With several transport and mast integration options, as well as its compact size, the HXI 150T is perfectly suited for smaller and more mobile rigs.

SAFE

- The integrated safety interlocks of the PLC system and driller's control panel maximize operating efficiency while minimizing risks.

WORLD CLASS SERVICE & SUPPORT

- TESCO's global network of service and support centers provides 24-hour operational and technical support, wherever in the world our equipment is operating.

SYSTEM OPTIONS

Rig Integration Packages:

Torque Restraint & Traveling Block Options:

- Removable torque track assembly
- Mast-integrated dolly system
- Integrated split-blocks

Power Unit Options:

- 500/700 hp Diesel Power Unit
- 500 hp Electric Power Unit
- Custom power solutions available upon request

Equipment Health Monitoring System:

- Real-Time monitoring and analysis of drilling equipment
- Improved performance and reliability

Anti-Collision System:

- Define and control acceptable operating limits for drilling equipment
- Prevent safety hazards and down-time



*Optional 180° pipehandler model

HXI 150T Top Drive

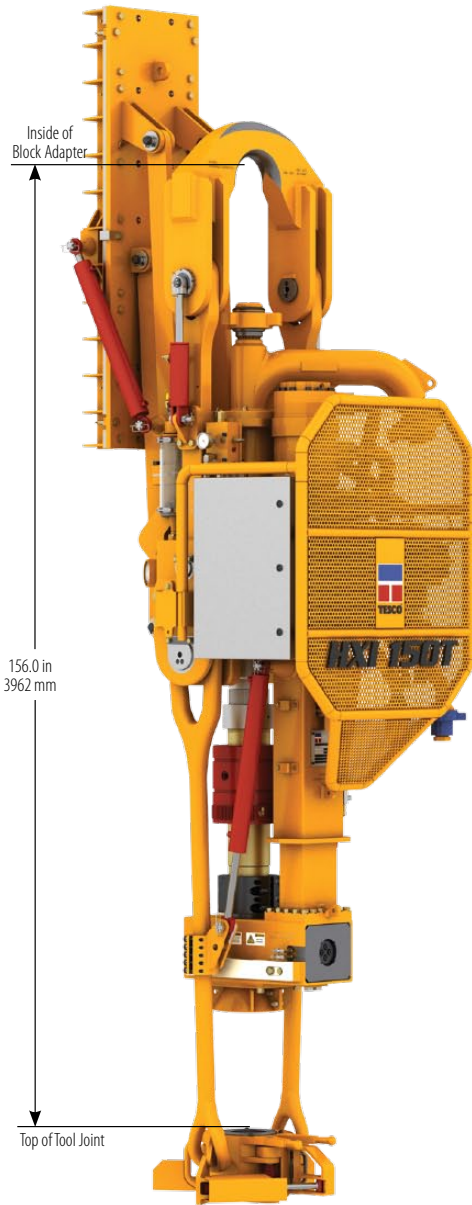
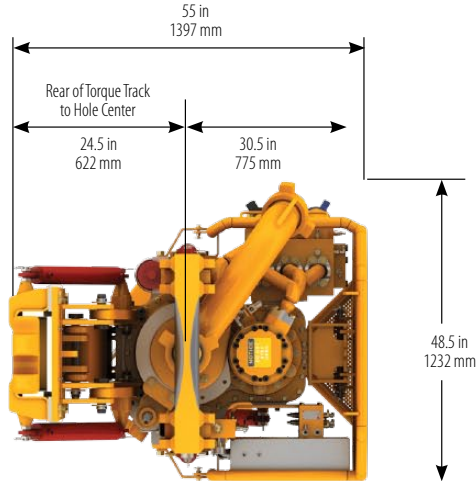

*Shown with removable torque track system and 7ft links

HXI 150T	Units	Specification
Rated Hoisting Capacity	ton	150
	tonne	136.0
API Dynamic Capacity	ton	150
	tonne	136.0
Pull Down Capacity (while circulating)	ton	25
	tonne	22.7
Maximum Continuous Drilling Torque	ft-lbs	24,000
	N-m	32,540
Make-up / Breakout Torque	ft-lbs	32,000
	N-m	43,386
Motor Type		Hydraulic
Maximum Rotational Speed	rpm	200
Gear Ratio		2.28:1
Selectable Speed Torque Output		High and Low
Approximate Weight	lbs	14,000
	kg	6,350
Operating Length Range (dependent on Block interface and Pipe Handling options)	feet	9 to 13
	m	2.74 to 3.96
Width	feet	4.04
	m	1.23
Swivel		Integrated
Maximum Operating Pressure	psi	7,500
	kPa	51,711
Quill Connection Type		NCSO (4-1/2 API IF)
Quill Inner Diameter	inches	3.0
	mm	76.2
Temperature Range - Top Drive	°F	-40 to +140
	°C	-40 to +60
Temperature Range - Hydraulic Power Unit	°F	-40 to +122 (Optional +131)
	°C	-40 to +50 (Optional +55)
	°F	-40 to +122 (Optional +131)
	°C	-40 to +50 (Optional +55)
Hydraulic Power Unit		ATC18 D4P 700hp
Remote Driller's Control Panel		YES
Mast Torque Arrest System	Standard	Mobile Torque Track
	Optional	Mast Integration
Grabber Box - Integral Back-Up Tong	inches	3 to 7.5
	mm	76.2 to 190.5
Dual-Ball Safety Valve - (IBOP)		Optional
Link-Tilt Pipe Handling System		Standard
180° Pipe Rotating System		Optional
Hydraulic Elevators		Optional
Automated Casing Running Tool Capable		YES
Transportable by Helicopter		YES

All specifications are subject to change without notice.

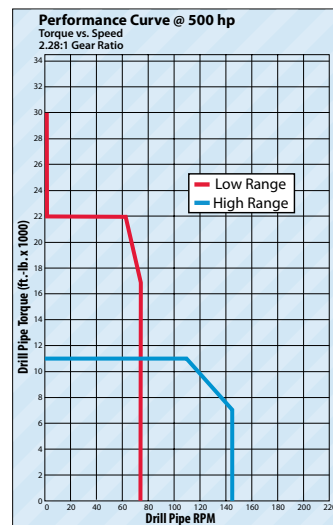
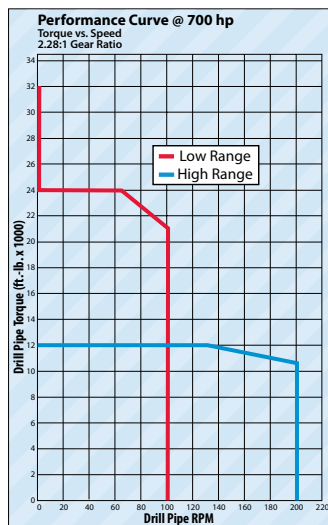

www.tescocom.com