



## 250 EMI 400 Top Drive



### The 250 ton, Model EMI 400HP Top Drive is a Full-Featured Electric Top Drive for Small-Mast Applications

**T**he 250 EMI 400 top drive system is the most versatile offering in TESCO's electric top drive line and is designed for use on offshore and land based drilling rigs.

The 250 EMI 400 provides the performance and pipe handling features required for drilling and workover applications.

The 250 EMI 400 employs an AC induction motor and drive system.

The 250 EMI 400 can be operated from a self-contained generator, or can be connected directly to the rig's AC Bus (600VAC- 50 or 60Hz). The EMI 400 is capable of producing 298kW (400HP).

#### Value Added Operational Benefits

- The complete system including the top drive, torque system, and optional VFD building can be installed in less than one day. Minimal rig modifications are necessary.
- The 250 EMI 400 is available with an optional genset. The drive can be independently packaged as a cabinet or building. The top drive can also be easily integrated with most existing drive configurations.
- The 250 EMI 400 offers all critical pipe-handling functions including elevator link-tilt, 137.2mm (5.4in.) extend/retract (for making mousehole connections), and 360° pipe handler rotation. The grabber will accommodate tool joints from 76.2mm (3in.) to 222.25mm (8-3/4in.) OD.

**Value Added Operational Benefits**

- The 250 EMI 400 top drive's unique design integrates the swivel, gearbox and load frame resulting in a very compact unit but maintains the serviceability expected from a TESCO top drive.
- The 250 EMI 400 system incorporates programmable logic control. PLC ensures flawless communication between the driller's panel and the drive system. The PLC system optimizes efficiency and provides important safety interlocks.
- The 250 EMI 400 package includes a customizable torque arrest system. The track/ torque bushing configuration is simple to install and requires minimal maintenance. A mud saver/safety valve is incorporated into the system design.
- The entire 250 EMI 400 top drive can be transported in three standard 6.09m (20ft.) sea containers and the top drive may be transportable in the mast for quick rig up.

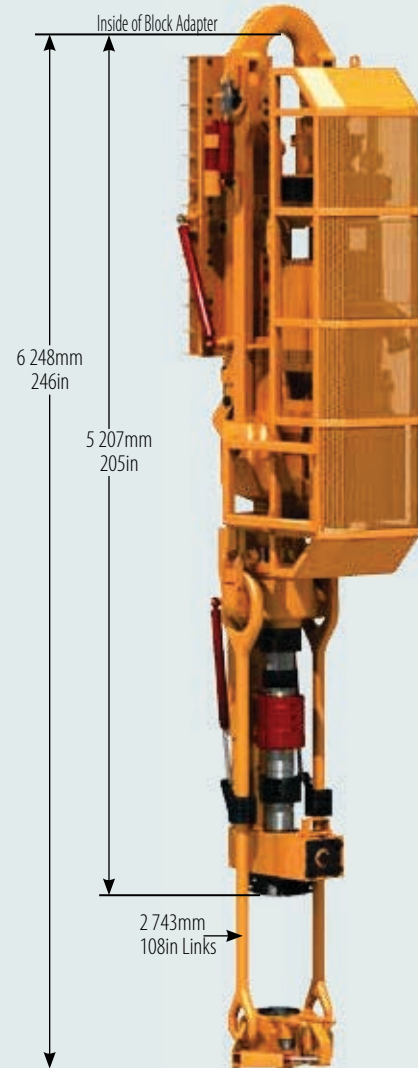
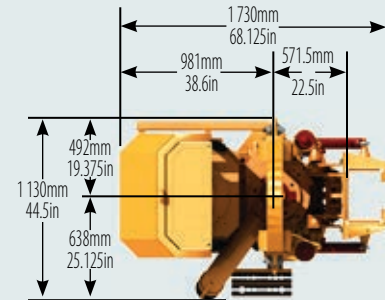

**Specifications**

250 TON EMI 400 HP (with a 250 ton integrated swivel)	Imperial	Metric
Rated Capacity	250ton	227tonne
Rated Power	400HP	298kW
Hook Weight	13,684lbs.	6 220kg
Operating Length (including 9 ft. links & elevators)	253in.	6 426mm
Width	44.5in.	1 730mm
Max. Continuous Drill Torque	21,000ft.-lb.	2 847daN-m
Make-up / Breakout Torque	32,000ft.-lb.	4 336daN-m
Max Speed	200RPM	200RPM
Quill ID	2.5in.	63.5mm
Quill Connection	NC50	

All specifications are subject to change without notice.

**Asia Pacific**

Jakarta, Indonesia  
Email: APBU\_sales@tescocorp.com

**China**

Chaoyang District, Beijing  
Email: CHINA\_sales@tescocorp.com

**Europe/Russia**

Moscow, Russia  
Email: EURO\_sales@tescocorp.com

**Latin America**

Mexico City, Mexico  
Email: LABU\_sales@tescocorp.com

**Middle East & Africa**

Dubai, UAE  
Email: MABU\_sales@tescocorp.com

**United States / Canada**

Houston, Texas / Calgary, Alberta  
Email: NABU\_sales@tescocorp.com

